



Pompa auto-adescente di tipo centrifugo adatta per approvvigionamento d'acqua (anche se miscelata a gas) in piccoli impianti domestici, accoppiate a serbatoi autoclave per il trasferimento di liquidi e svuotamento di serbatoi; utilizzate in applicazioni industriali di media entità e per il giardinaggio.

Self-priming centrifugal pump for water supplies (even if mixed with gas) in small household systems, connected to autoclave tanks for transferring liquids and emptying tanks; used in medium sized industrial applications and for gardening.

Bomba auto-aspirante de tipo centrifugo para el suministro de agua (aunque esté mezclada con gas) en pequeñas instalaciones domésticas, acopladas en equipos de presión para la transferencia de líquidos y el vaciado tanques; utilizadas en aplicaciones industriales de media importancia y para la jardinería.

Pompe auto-amorçante de type centrifuge, apte à l'approvisionnement d'eau (même si mélangée à des gaz) dans les petites installations domestiques, l'accouplement à des réservoirs, le transfert de liquides et le vidage de réservoirs; peut être utilisée dans des applications industrielles de moyenne entité et pour le jardinage.

**CARATTERISTICHE COSTRUTTIVE / CONSTRUCTION FEATURES
CARACTERÍSTICAS CONSTRUCTIVAS / CARACTÉRISTIQUES D'EXÉCUTION**

Corpo pompa	acciaio AISI 304
Pump body	stainless steel AISI 304
Cuerpo bomba	acero AISI 304
Corps de pompe	acier AISI 304
Supporto motore	alluminio
Motor bracket	aluminium
Soporte motor	aluminio
Support moteur	aluminium
Girante	Noryl® o acciaio AISI 304, Noryl® (JXFR)
Impeller	Noryl® or stainless steel AISI 304, Noryl® (JXFR)
Rodete	Noryl® o acero AISI 304, Noryl® (JXFR)
Turbine	Noryl® ou acier AISI 304, Noryl® (JXFR)
Tenuta meccanica	ceramica-grafite
Mechanical seal	ceramic-graphite
Sello mecánico	cerámica-grafito
Garniture mécanique	céramique-graphite
Albero motore	acciaio AISI 416
Motor shaft	stainless steel AISI 416
Eje motor	acero AISI 416
Arbre moteur	acier AISI 416
Temperatura del liquido	
Liquid temperature	0 - 50 °C
Temperatura del líquido	
Température du liquide	
Pressione di esercizio	
Operating pressure	max 6 bar
Presión de trabajo	
Pression de fonctionnement	
MOTORE / MOTOR / MOTOR / MOTEUR	
Motore 2 poli a induzione	3~ 230/400V-50Hz
2 pole induction motor	1~ 230V-50Hz
Motor de 2 polos a inducción	con termoprotettore
Moteur à induction à 2 pôles	with thermal protection
	con protección térmica
	avec protection thermique
Classe di isolamento	
Insulation class	F
Clase de aislamiento	
Classe d'isolation	
Grado di protezione	
Protection degree	IP44
Grado de protección	
Protection	

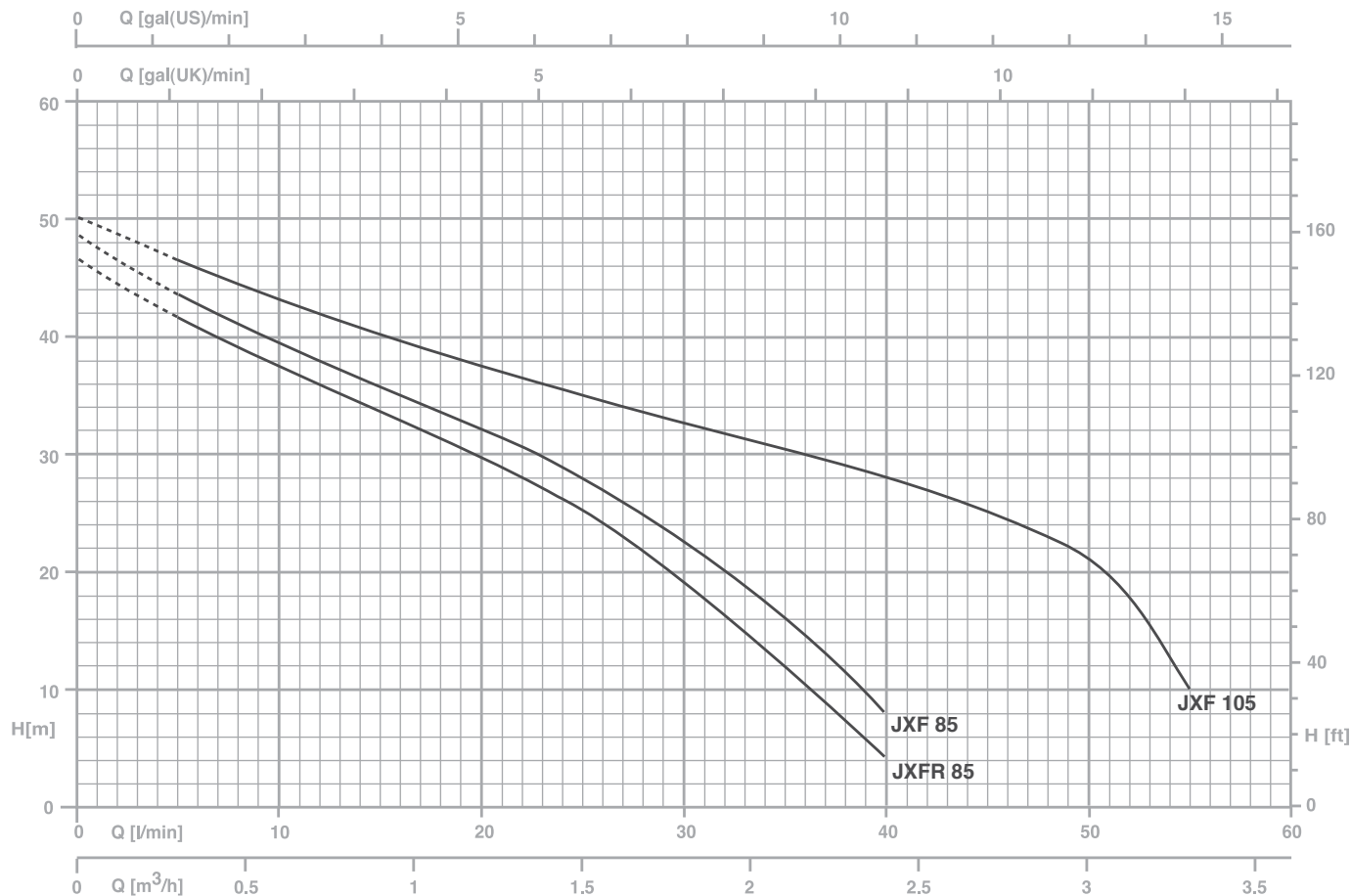

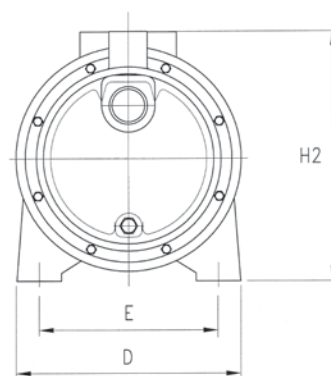
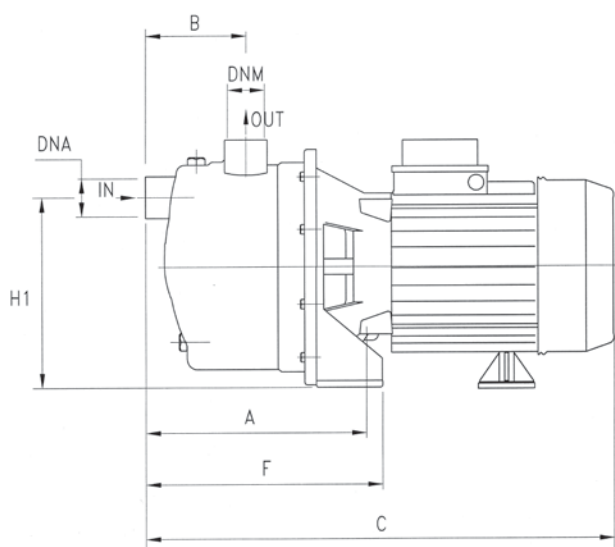

TYPE		P2		P1 (kW)		AMPERE		Q (m³/h - l/min)					
1~	3~	(HP)	(kW)	1~	3~	1x230 V 50 Hz	3x400 V 50 Hz	0	0,6	1,2	1,8	2,4	3
								0	10	20	30	40	50
								H (m)					
JXFR 85	JXFR 85 T	0,8	0,59	0,78	0,79	3,6	1,4	46,5	37	29,5	19,2	4	-
JXF 85	JXF 85 T	0,8	0,59	0,79	0,79	3,7	1,4	48,5	39	32	22,4	7,6	-
JXF 105	JXF 105 T	1	0,74	0,98	1	4,6	2,2	50	43	38	32	28	21

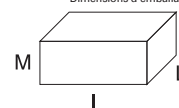

Dimensioni imballo
Package dimensions
Dimensions emballage
Dimensions d'emballage



TYPE	DIMENSIONS (mm)													
	A	B	C	D	E	F	H1	H2	DNA	DNM	I	L	M	
JXFR 85	165	79	352	175	140	175	150	199	1" G	1" G	400	210	235	7.9
JXF 85	165	79	360	175	140	175	150	199	1" G	1" G	400	210	235	8.7
JXF 105	165	79	360	175	140	175	150	199	1" G	1" G	400	210	235	9.9